

BTM is an associate company of Akay Industries Pvt Ltd

chemflo[®]



chemflo[®]



BTM PROCESS CONTROLS PVT LTD.

Address: Plot No 162/A&162/B Gamanagatti Industrial Estate
Hubballi Karnataka 580024 | Tel: +91 (0) 836-2486001/02

Email: business@btmprocesscontrols.com

Web: www.btmprocesscontrols.com



TYPE AFP
AXIAL FLOW PUMPS

AFP FEATURES

AFP FEATURES

① SPLIT BEARING FRAME
For ease of maintenance.

② CASING
Top or end section with class 150 flanges.

③ HEAVY DUTY SHAFT
Designed for most severe operating conditions minimum deflection at maximum load.

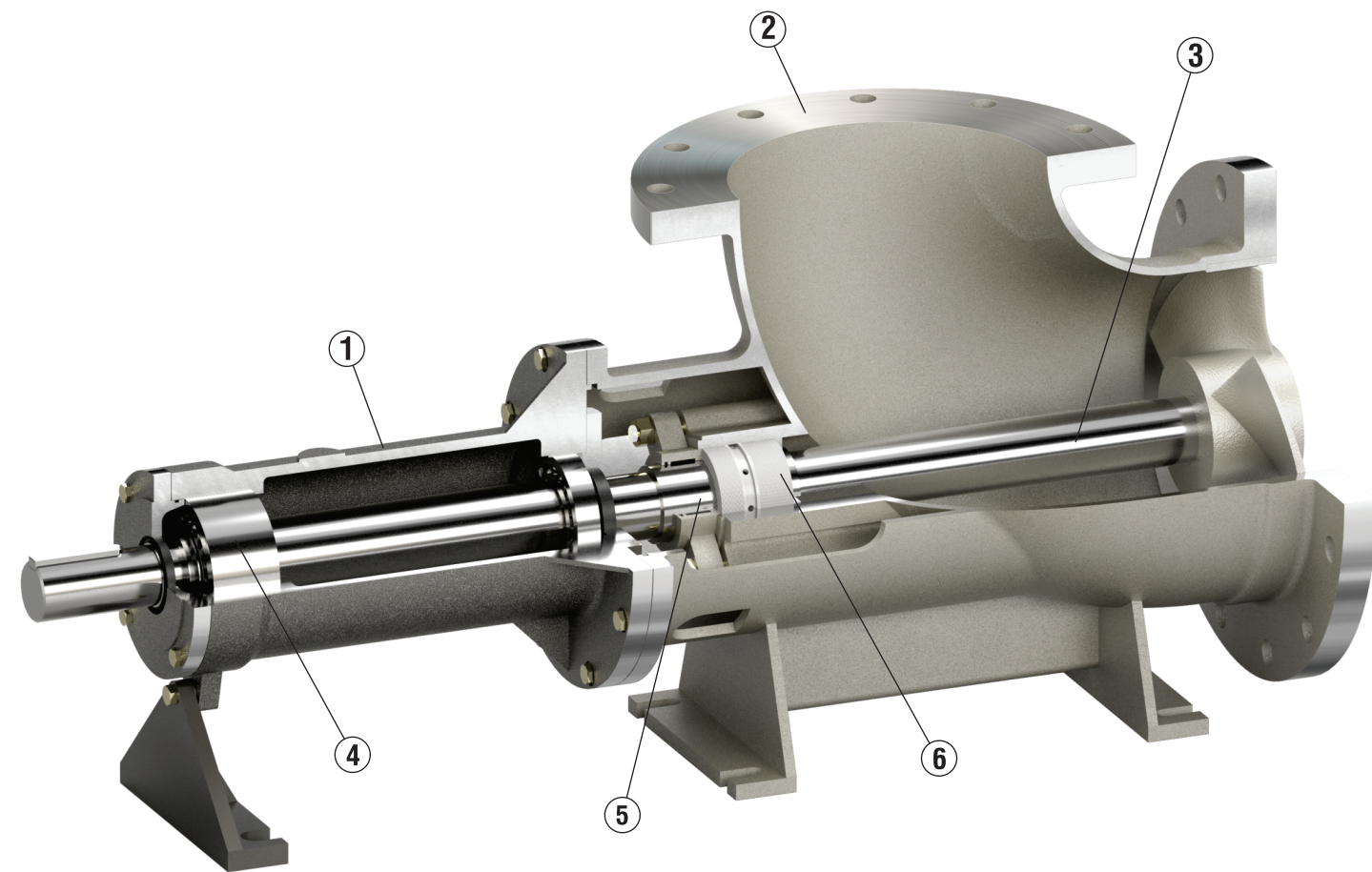

④ DOUBLE ROW THRUST BEARING
Keeps end play less than 0.025 mm for maximum seal life. Bearing sized for L10 rating life of minimum 2 years.

⑤ RENEWABLE SHAFT SLEEVE
Simplifies maintenance.

⑥ SEALING FLEXIBILITY
Packed box standard. Wide range of Chemflo mechanical seals can be accommodated.

RANGE

- Capacity to 15000 m³/h
- Head to 9 m
- Temperature to 180° C
- Pressure to 1600 kPa

FEATURES

- Axial flow impeller blade designed for optimum efficiency using aerofoils.
- Pump can be used either in end or top suction depending on piping configuration.
- Shaft engineered to give deflection less than 0.05mm
- Grease Lubrication.
- Various arrangements of chemflo mechanical seal can be accommodated.

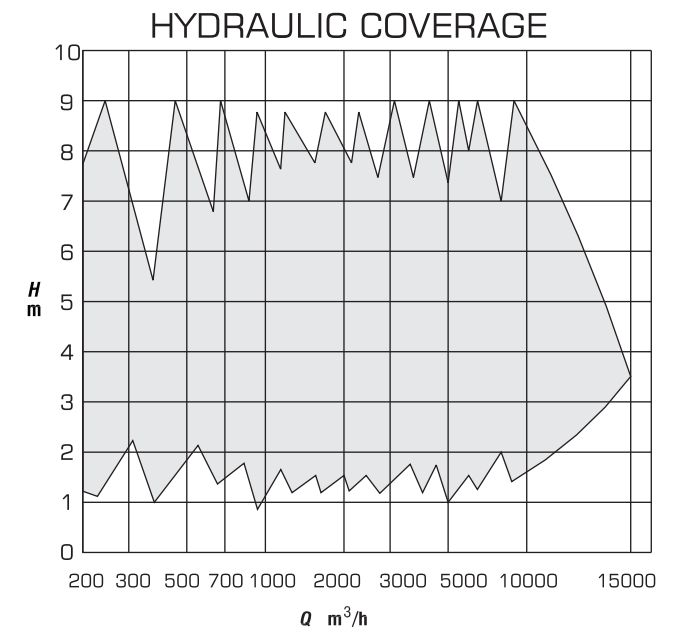

DIMENSIONS

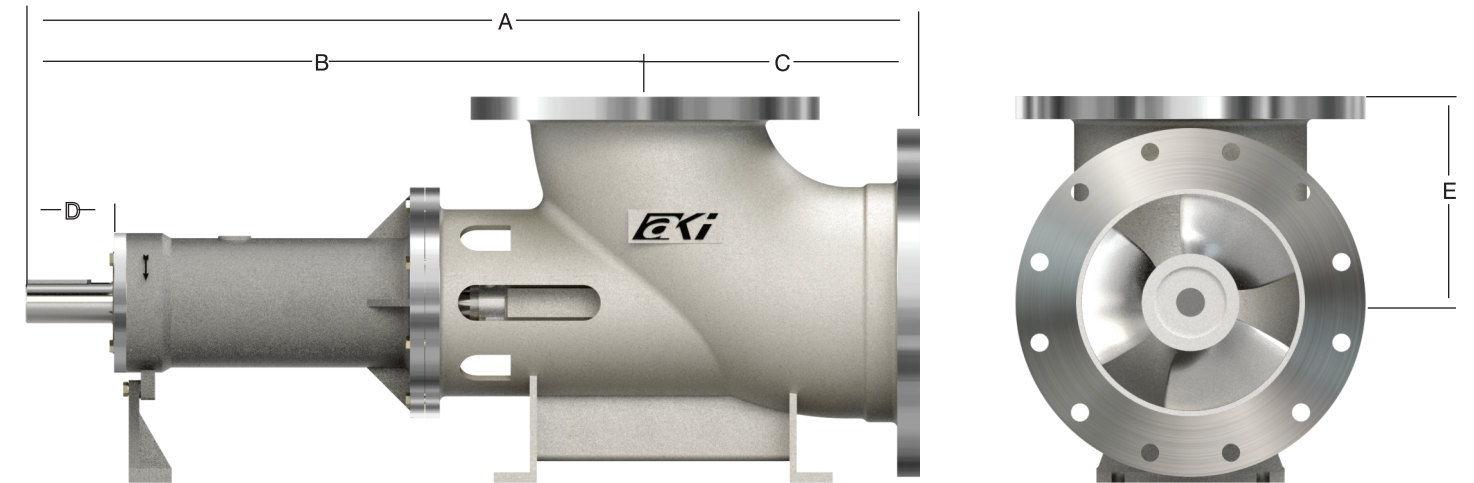

DIM	PUMP SIZE											
	6	8	10	12	14	16	18	20	24	28	30	36
A	791	843	927	1305	1384	1584	1645	1918	2057	2451	2261	2781
B	594	589	610	924	940	1076	1073	1283	1295	1575	1600	1765
C	197	254	318	381	445	508	572	635	762	876	927	1016
D	152	86	86	119	119	152	152	183	183	203	203	210
E	156	191	238	286	333	381	429	476	572	648	635	711